

# MARTIN HUXFORD

## MINOS WALL LIGHT

The Minos plaster white wall sconce is an exciting mix of neo-classical and contemporary art influences, from ancient Greek myth to Picasso's use of the bull as cultural metaphor. Martin's abstract vision of this enduring classical myth brings a simple power and depth to his hand sculpted design.

Shown in Plaster White with Dijon cotton shades.

### Dimensions

Height 46cm 18" excluding shade

Width 36cm 14"

Depth 21cm 8"

Weight 3kg 7lbs

Recommended shade: 18x19cm 7x7.5"

### Finishes

Plaster White

### Materials

Hand-cast Jesmonite

### Dimming

Yes

### Lamping

2x E12 LED Max 7W 120V

Handmade in England

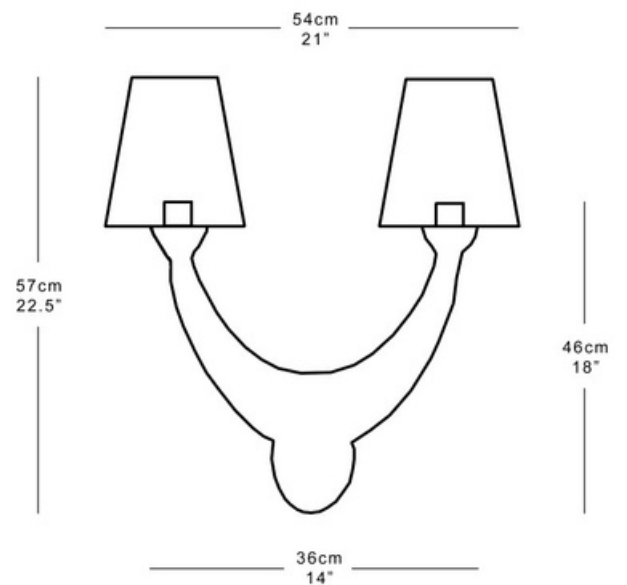

# MARTIN HUXFORD

WALL FITTING

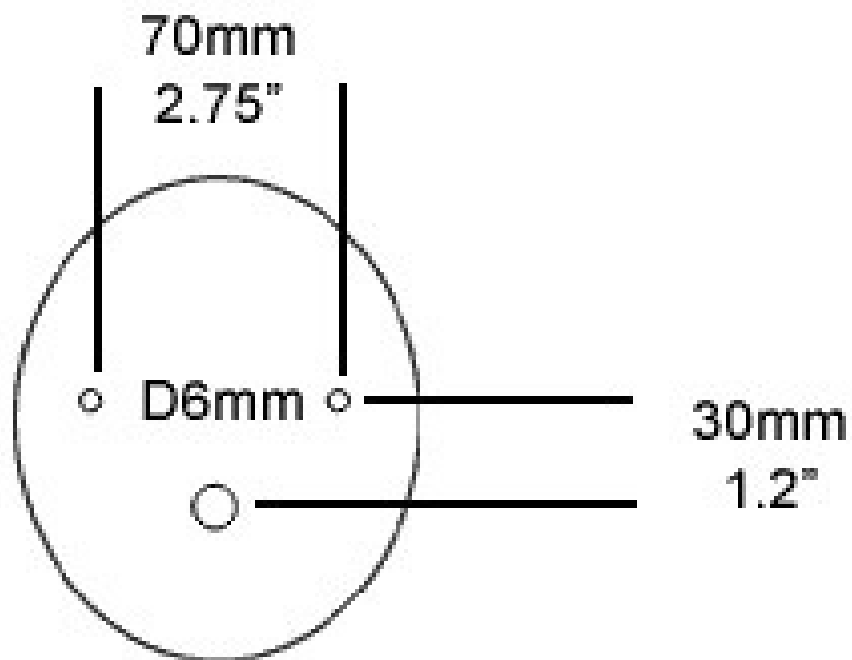

# Cotton samples

