

Cirque Floor-to-ceiling Ellipse Vertical

CQFCEV

 IP20

Materials

Transparent borosilicate glass and hand finished brass.

Power Input

110-120V 50-60Hz

Light Source (included)

4 Proprietary Cirque LEDs.
12W, 1600Lumens, 2700K warm white.
CRI>95.

Available on request with two poles US power plug with entrance at the base. Foot switch includes dimmer. Assembled with UL/UR components. UL approved only for ceiling supply connection.

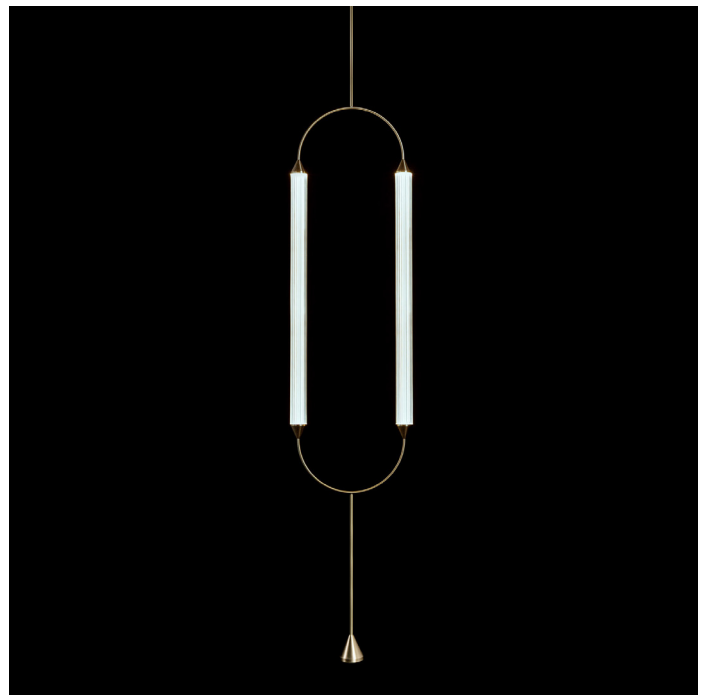

CIRQUE FLOOR-TO-CEILING ELLIPSE VERTICAL 90

CONFIGURATION

STEP 1 - CHOOSE YOUR SIZE

SIZE (UNIT: IN)

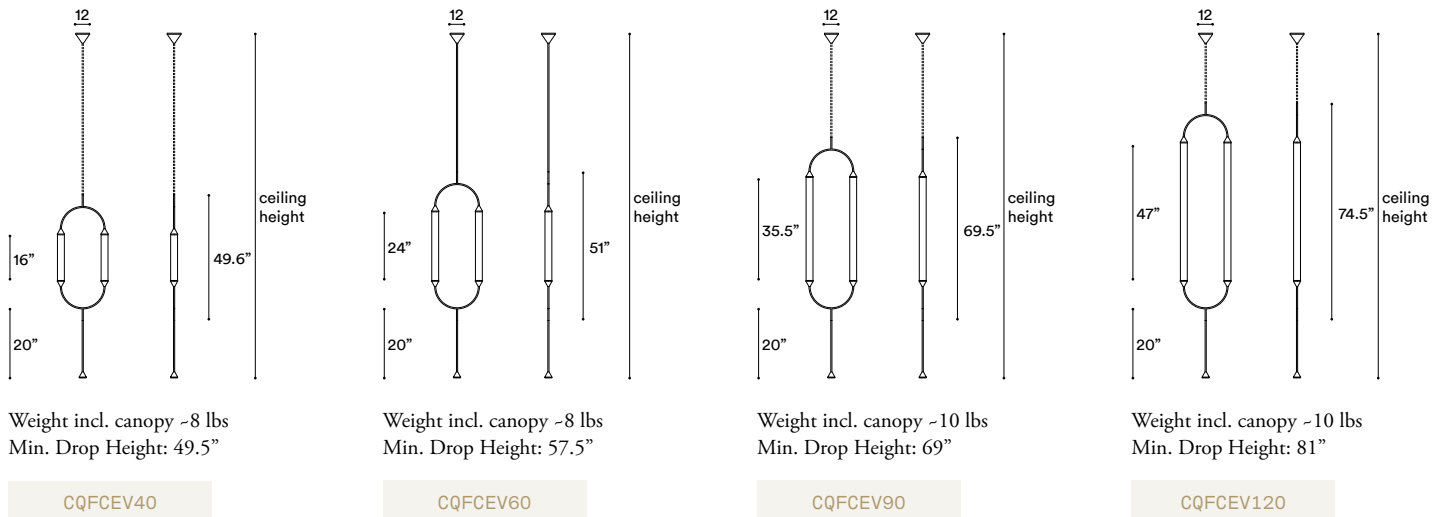

STEP 2 - CHOOSE YOUR METAL FINISH

METAL FINISH

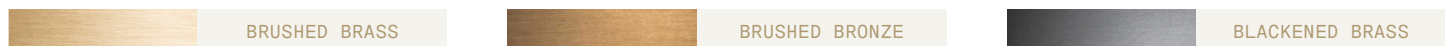

STEP 3 - CHOOSE YOUR CEILING HEIGHT

CEILING HEIGHT

Metal tube suspension

Specify your Ceiling height in inches to our sales team.

Note:
No cable showing
Not adjustable on site

MADE TO ORDER

+ **Single ceiling canopy with built-in phasecut driver.** Recommended.

Ø4.5" X H4"



MATCHING FINISH

PHASECUT

+ **Single ceiling canopy with built-in driver and alternative dimmable standards,** if required by electrician.

Ø4.5" X H4"



MATCHING FINISH

1-10 VOLT

Brushed Brass

Brass hand finished with horizontal brushing. Protected with a semi-gloss transparent coating.

Brushed Bronze

Brass with accelerated aging to become a bronze finish. Hand finished with horizontal brushing. Protected with a semi-matt transparent coating.

Blackened Brass

Brass with accelerated aging to become an extra dark chocolate finish. Hand finished with horizontal brushing. Protected with a semi-matt transparent coating.

Brushed Nickel

Electroplated nickel over Brass with horizontal brushing. Protected with a semi-gloss transparent coating.

Polished Nickel

Electroplated Nickel over polished brass. Protected with a semi-gloss transparent coating.

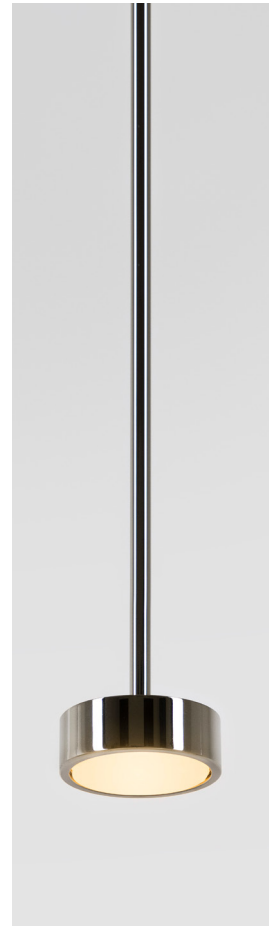

Custom Finish

Our products can be customized with most metal finishes, please check with our design advisors if you have any particular requirement.

Please advise if our products are to be installed close to air conditioning vents or in windy or salty air conditions.